



Dough Roller
Model BE-CN-0400
Item 39638
Instruction Manual



Revised - 08/31/2020



Toll Free: 1-800-465-0234
Fax: 905-607-0234
Email: service@omcan.com
www.omcan.com

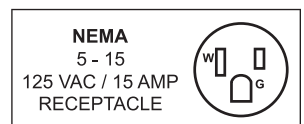

Table of Contents

Model BE-CN-0400

Section	Page
General Information -----	3 - 4
Safety and Warranty -----	4 - 5
Technical Specification -----	6
Installation -----	6
Operation -----	6 - 7
Maintenance -----	7 - 8
Troubleshooting -----	8
Parts Breakdown -----	9 - 10
Electrical Schematics -----	11
Notes -----	12 - 14
Warranty Registration -----	15



General Information

Omcan Manufacturing and Distributing Company Inc., Food Machinery of America, Inc. dba Omcan and Omcan Inc. are not responsible for any harm or injury caused due to any person's improper or negligent use of this equipment. The product shall only be operated by someone over the age of 18, of sound mind, and not under the influence of any drugs or alcohol, who has been trained in the correct operation of this machine, and is wearing authorized, proper safety clothing. Any modification to the machine voids any warranty, and may cause harm to individuals using the machine or in the vicinity of the machine while in operation.

CHECK PACKAGE UPON ARRIVAL

Upon receipt of an Omcan shipment please inspect for external damage. If no damage is evident on the external packaging, open carton to ensure all ordered items are within the box, and there is no concealed damage to the machine. If the package has suffered rough handling, bumps or damage (visible or concealed), please note it on the bill of lading before accepting the delivery and contact Omcan within 24 hours, so we may initiate a claim with the carrier. A detailed report on the extent of the damage caused to the machine must be filled out within three days, from the delivery date shown in the shipping documents. Omcan has no recourse for damaged products that were shipped collect or third party.

Before operating any equipment, always read and familiarize yourself with all operation and safety instructions.

Omcan would like to thank you for purchasing this machine. It's of the utmost importance to save these instructions for future reference. Also save the original box and packaging for shipping the equipment if servicing or returning of the machine is required.

Omcan Fabrication et distribution Compañie Limité et Food Machinery d'Amérique, dba Omcan et Omcan Inc. ne sont pas responsables de tout dommage ou blessure causé du fait que toute personne ait utilisé cet équipement de façon irrégulière. Le produit ne doit être exploité que par quelqu'un de plus de 18 ans, saine d'esprit, et pas sous l'influence d'une drogue ou d'alcool, qui a été formé pour utiliser cette machine correctement, et est vêtu de vêtements de sécurité approprié. Toute modification de la machine annule toute garantie, et peut causer un préjudice à des personnes utilisant la machine ou des personnes à proximité de la machine pendant son fonctionnement.

VÉRIFIEZ LE COLIS DÈS RÉCEPTION

Dès réception d'une expédition d'Omcan veuillez inspecter pour dommages externes. Si aucun dommage n'est visible sur l'emballage externe, ouvrez le carton afin de s'assurer que tous les éléments commandés sont dans la boîte, et il n'y a aucun dommage dissimulé à la machine. Si le colis n'a subi aucune mauvaises manipulations, de bosses ou de dommages (visible ou cachée), notez-le sur le bond de livraison avant d'accepter la livraison et contactez Omcan dans les 24 heures qui suivent, pour que nous puissions engager une réclamation auprès du transporteur. Un rapport détaillé sur l'étendue des dommages causés à la machine doit être rempli dans un délai de trois jours, à compter de la date de livraison indiquée dans les documents d'expédition. Omcan n'a aucun droit de recours pour les produits endommagés qui ont été expédiés ou cueilli par un tiers transporteur.

General Information

Avant d'utiliser n'importe quel équipement, toujours lire et vous familiariser avec toutes les opérations et les consignes de sécurité.

Omcan voudrais vous remercier d'avoir choisi cette machine. Il est primordial de conserver ces instructions pour une référence ultérieure. Également conservez la boîte originale et l'emballage pour l'expédition de l'équipement si l'entretien ou le retour de la machine est nécessaire.

Omcan Empresa De Fabricacion Y Distribucion Inc. Y Maquinaria De Alimentos De America, Inc. dba Omcan y Omcan Inc. no son responsables de ningun daño o perjuicio causado por cualquier persona inadecuada o el uso descuidado de este equipo. El producto solo podra ser operado por una persona mayor de 18 años, en su sano juicio y no bajo alguna influencia de droga o alcohol, y que este ha sido entrenado en el correcto funcionamiento de esta máquina, y ésta usando ropa apropiada y autorizada. Cualquier modificación a la máquina anula la garantía y puede causar daños a las personas usando la máquina mientras esta en el funcionamiento.

REVISE EL PAQUETE A SU LLEGADA

Tras la recepcion de un envio Omcan favor inspeccionar daños externos. Si no hay daños evidentes en el empaque exterior, Habra el carton para asegurarse que todos los articulos solicitados estén dentro de la caja y no encuentre daños ocultos en la máquina. Si el paquete ha sufrido un manejo de poco cuidado, golpes o daños (visible o oculto) por favor anote en la factura antes de aceptar la entrega y contacte Omcan dentro de las 24 horas, de modo que podamos iniciar una reclamación con la compañía. Un informe detallado sobre los daños causados a la máquina debe ser llenado en el plazo de tres días, desde la fecha de entrega que se muestra en los documentos de envío. Omcan no tiene ningun recurso por productos dañados que se enviaron a recoger por terceros.

Antes de utilizar cualquier equipo, siempre lea y familiarizarse con todas las instrucciones de funcionamiento y seguridad.

Omcan le gustaría darle las gracias por la compra de esta máquina. Es de la mayor importancia para salvar estas instrucciones para futuras consultas. Además, guarda la caja original y el embalaje para el envío del equipo si servicio técnico o devolución de la máquina que se requiere.

Safety and Warranty

WARNING

PLEASE READ THE USER MANUAL CAREFULLY BEFORE OPERATING THE MACHINE.

Warning: To avoid dangerous conditions and/or possible injuries caused by the electrical current, mechanical parts, fire or unhygienic situations, you must follow everything listed below:

Safety and Warranty

- Keep the working area clean.
- Do not use the machine in humid, wet or badly lit environments, or close to inflammable liquids or gases.
- Keep children and unauthorized personnel away from the unit.
- Do not touch the machine with wet hands.
- Only use the machine with the correct voltage rating.
- Do not wear hanging clothes or any items which can be caught in the machine. Use non-slip shoes. For hygiene and safety, keep your hair tied back and wear protective gloves.
- Do not pull on the cable to remove the plug. Do not place the cable near high temperatures, sharp objects, or liquids.
- Always unplug the machine when it is not in use, before cleaning, maintenance or when moving it.
- Before using the machine, carefully check that all safety devices are working, that the removable parts are not blocked, none of the parts are damaged, and all the parts have been set up correctly.
- When the machine is damaged or there are problems with the machine, you must turn off the machine and call Omcan. The repairs can only be done by qualified technicians, using original spare parts.

1 YEAR PARTS AND LABOUR BENCH WARRANTY

Within the warranty period, contact Omcan Inc. at 1-800-465-0234 to schedule a drop off to either an Omcan authorized service depot in the area, or to an Omcan Service warehouse to repair the equipment.

Unauthorized maintenance will void the warranty. Warranty covers electrical and part failures, not improper use.

Please see <https://omcan.com/disclaimer> for complete info.

WARNING:

The packaging components are classified as normal solid urban waste and can therefore be disposed of without difficulty.

In any case, for suitable recycling, we suggest disposing of the products separately (differentiated waste) according to the current norms.

DO NOT DISCARD ANY PACKAGING MATERIALS IN THE ENVIRONMENT!

Technical Specifications

Model	BE-CN-0400
Power	0.5 HP / 0.37 kW
Dough Weight	1.8 - 17.6 oz. / 50 - 500g
Pizza Diameter	4" - 16" / 102 - 406mm
Electrical	110V / 60Hz / 1
Dimensions	20.9" x 20.9" x 25.6" / 530 x 530 x 650mm
Packaging Dimensions	22.8" x 23.2" x 32.7" / 580 x 590 x 830mm
Packaging Weight	123.2 lbs. / 56 kgs.
Item Number	39638

Installation

Remove the protective film, avoid using utensils that can damage the surface of the unit, check that the machine is not damaged. Please contact Omcan in the event that the machine is damaged.

The machine must be installed in a dry, adequately ventilated and well lit environment. Position the machine on a flat and stable surface; you can put it on a workbench of comfortable height (about 700 - 900mm / 27.6" - 35.4"), and leave a space of 150mm / 5.9" around the machine for easy access and cleaning.

It is necessary to check the cable carefully and verify that it is not damaged before putting the plug into the receptacle. The receptacle must be easily accessible. The cable from the machine to the receptacle must not be pulled tightly, and the machine must not rest on the cable.

Note: The machine has been installed and tested by technical personal before leaving the factory, and it is qualified for use. The machine must not be disassembled or modified in any way, or the warranty will be voided.

Operation

The machine has the following controls:

- A - Red button to stop the machine.
- B - Green button to start the machine.

Functional test

After plugging the machine in, the machine is ready for the functional test.

To start: press the green button, the machine starts working.

To stop: press the red button, the machine will stop working.

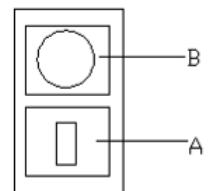

Operation

Start the machine without loading, let it run for one minute and make sure it is functioning properly.

Before every work-cycle, always make sure the machine is perfectly clean, in particular, any surface that comes in contact with dough. If necessary clean the machine.

Warning: Keep small items and hands away from the rollers before you turn on the machine!

Operation for the shaping of round disks

After turning on the machine, you can put a small amount of dough (50-500g) which has been previously fermented for at least 4 to 6 hours. Squash the sides slightly and put some dry flour on it so it can easily go through the upper rollers (Pic.1).

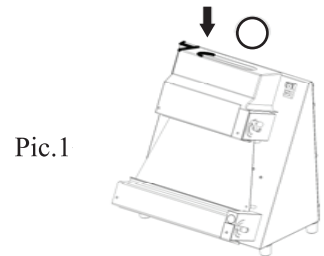

When the dough comes out from the upper roller, you will receive thin dough with an oval shape. Turn the dough 90° by hand, and it will be ready for the next step to travel through the lower rollers. Out of these rollers it will have an imperfect round shape, to get the shape to the desired roundness, you must finish forming it by hand (Pic.2).

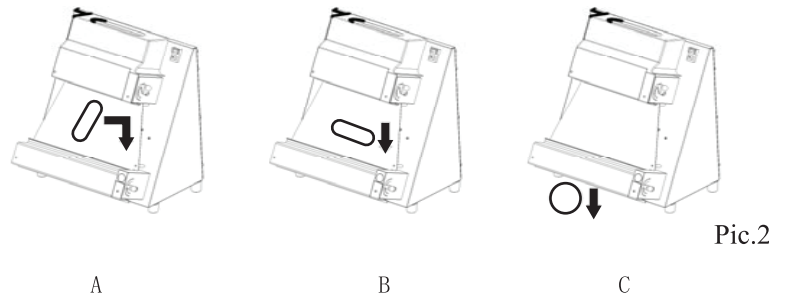

Operation for the shaping of rectangles, squares, and other shapes

If you want to obtain a different shape in your dough, you can cut the dough to the approximate shape, for example squares, rectangle etc. with a knife or a special tool, before putting the dough through one or both rollers.

How to adjust the thickness

Adjusting the machines thickness is recommended as the weight, the thickness, the size and the shape of the disk will never be the same. To obtain different thickness in your dough, you must do the following:

- Turn off the machine.
- Adjust the width between the highest rollers. Pull the black knot in order to release the lever, and then turn the lever to a proper position. Clockwise is to reduce the thickness, counterclockwise is to increase the thickness (Pic.3).

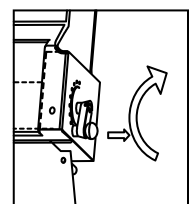

Pic. 3

Maintenance

Before starting any kind of maintenance or cleaning you must remove the plug from the socket. It is important not to use any chemical, abrasive or corrosive products. Do not use running water, or abrasive tools, such as metal wool etc; these can damage the unit and compromise the hygienic safety.

Maintenance

Cleaning must be done every time after use, failure to do so will cause the machine to malfunction and will compromise the hygienic safety of the unit.

Using a proper brush and a wooden palate, first clean the residue of flour and dough from the unit. Disassemble the covers, the two slides, and the release springs, remove the dough pieces then turn the regulating levers so that the rollers will be in the fully opened position. Carefully clean the machine and the disassembled parts using a damp sponge or cloth with water and detergent. Rinse and dry thoroughly with an absorbing food-paper, wipe all surfaces that come in contact with the dough and then clean the whole machine with a smooth cloth and a specific disinfectant for food machines. Reassemble the unit when cleaning is completed.

Lubrication of shafts and rollers

It is necessary to grease shafts and rollers every year. Disassemble the covers, the slanted wall, the springs and the dough-scrappers; unscrew the fixing screws and take off the back-panel first and then the stands; then remove the rollers and the joints. Clean all these parts carefully by means of a sponge with warm water and food detergent, rinse thoroughly and dry it with absorbing paper. Grease the shafts and the rollers holes with a sufficient amount of paraffin oil. Reassemble the unit when done.

Troubleshooting

Problem	Cause	Solution
The machine does not start.	The unit is not plugged in.	Plug the unit into the socket.
	The input voltage is incorrect.	Use the proper input voltage.
		Call Omcan for further assistance.
The machine conducts electricity.	The wires touch the body of the machine.	Check the wires, verify the wires do not touch the body of the machine.
Only a group of roller are working.	The belt is broken.	Change the belt.
	The worm wheel is worn out.	Change the worm wheel.

REFERENCE

Item Number	Model Number	Description	Manufacturer Model Number
39638	BE-CN-0400	Pizza Dough Moulder 0.5 HP 120/60 cETLus	DR-1V

Parts Breakdown

Model **BE-CN-0400** 39638

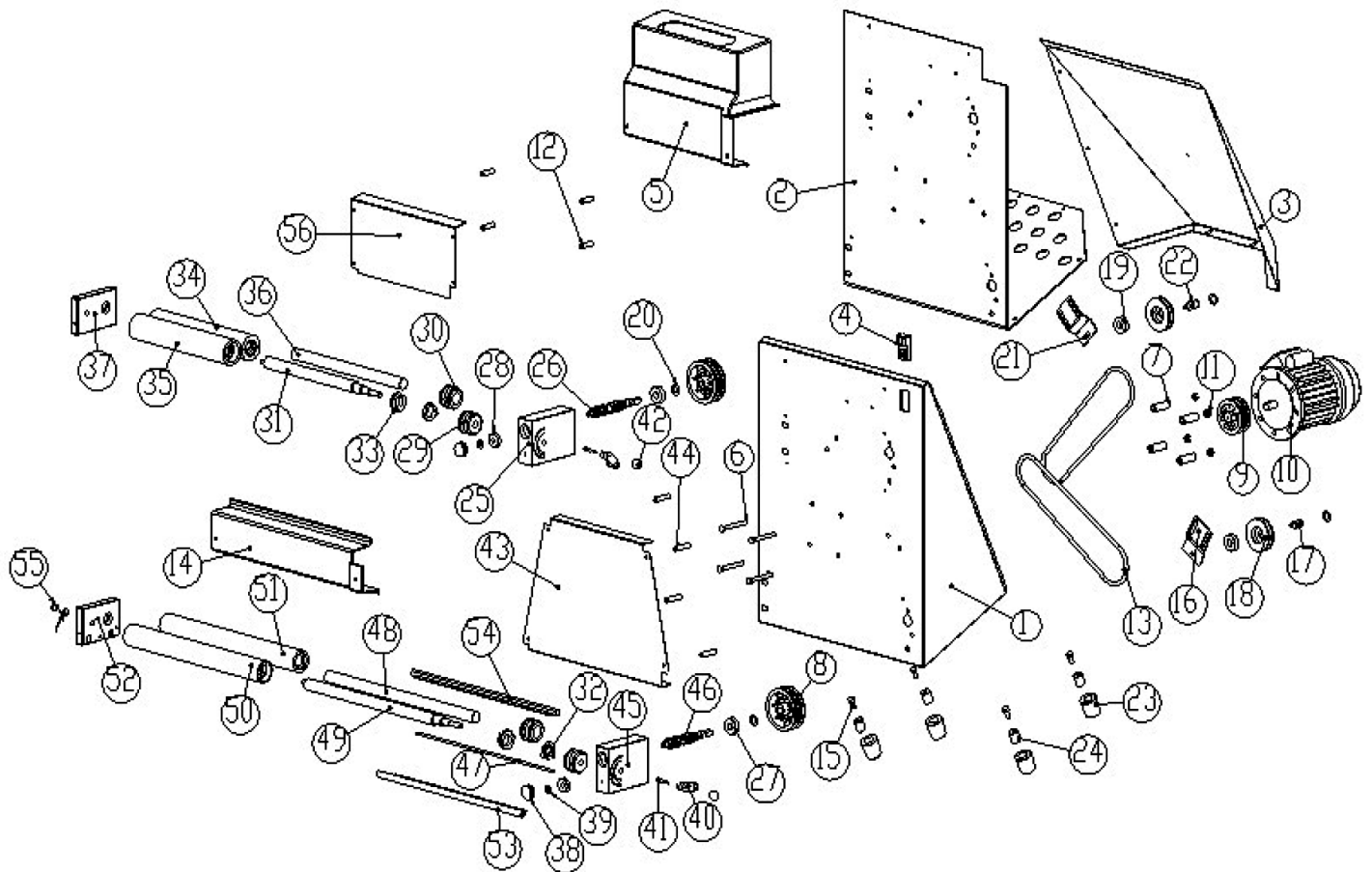

Parts Breakdown

Model BE-CN-0400 39638

Item No.	Description	Position	Item No.	Description	Position	Item No.	Description	Position
41970	Body for DR-1V	1	41989	Ring for DR-1V	20	42008	Ring for DR-1V	39
41971	Board for DR-1V	2	41990	Fix Block A for DR-1V	21	42009	Ball Handle for DR-1V	40
41972	Back Cover for DR-1V	3	41991	Locating Shaft A for DR-1V	22	42010	Bar for DR-1V	41
41973	Switch for DR-1V	4	41992	Rubber Foot for DR-1V	23	42011	Ball Handle for DR-1V	42
41974	Up Cover for DR-1V	5	41993	Rubber Bar for DR-1V	24	42012	Lower Plate for DR-1V	43
41975	Screw for DR-1V	6	41994	Supporter-B for DR-1V	25	42013	Supporter Bar-A for DR-1V	44
41976	Supporting Tube for DR-1V	7	41995	Worm-A for DR-1V	26	42014	Supporter-C for DR-1V	45
41977	Belt Wheel-B for DR-1V	8	41996	Axle Tree-A for DR-1V	27	42015	Worm-B for DR-1V	46
41978	Belt Wheel-A for DR-1V	9	41997	Axle Tree-B for DR-1V	28	42016	Supporting Axle for DR-1V	47
41979	Motor for DR-1V	10	41998	Worm Wheel-A for DR-1V	29	42017	Roller Shaft-A for DR-1V	48
41980	Nut for DR-1V	11	41999	Worm Wheel-B for DR-1V	30	42018	Eccentric Axle-B for DR-1V	49
41981	Supporter Bar-B for DR-1V	12	42000	Eccentric Axle-A for DR-1V	31	42019	Roller-C for DR-1V	50
41982	Belt for DR-1V	13	42001	Transit Ring for DR-1V	32	42020	Roller-A for DR-1V	51
41983	Low Cover for DR-1V	14	42002	Transit Ring for DR-1V	33	42021	Supporter-D for DR-1V	52
41984	Screw for DR-1V	15	42003	Roller-B for DR-1V	34	42022	Scraper-A for DR-1V	53
41985	Fix Block B for DR-1V	16	42004	Roller-D for DR-1V	35	42023	Scraper-B for DR-1V	54
41986	Locating Shaft B for DR-1V	17	42005	Roller Shaft-B for DR-1V	36	42024	Spring for DR-1V	55
41987	Tension Wheel for DR-1V	18	42006	Supporter-A for DR-1V	37	42025	Upper Plate for DR-1V	56
41988	Bearing for DR-1V	19	42007	Cover for DR-1V	38			

Electrical Schematics

Model **BE-CN-0400** 39638

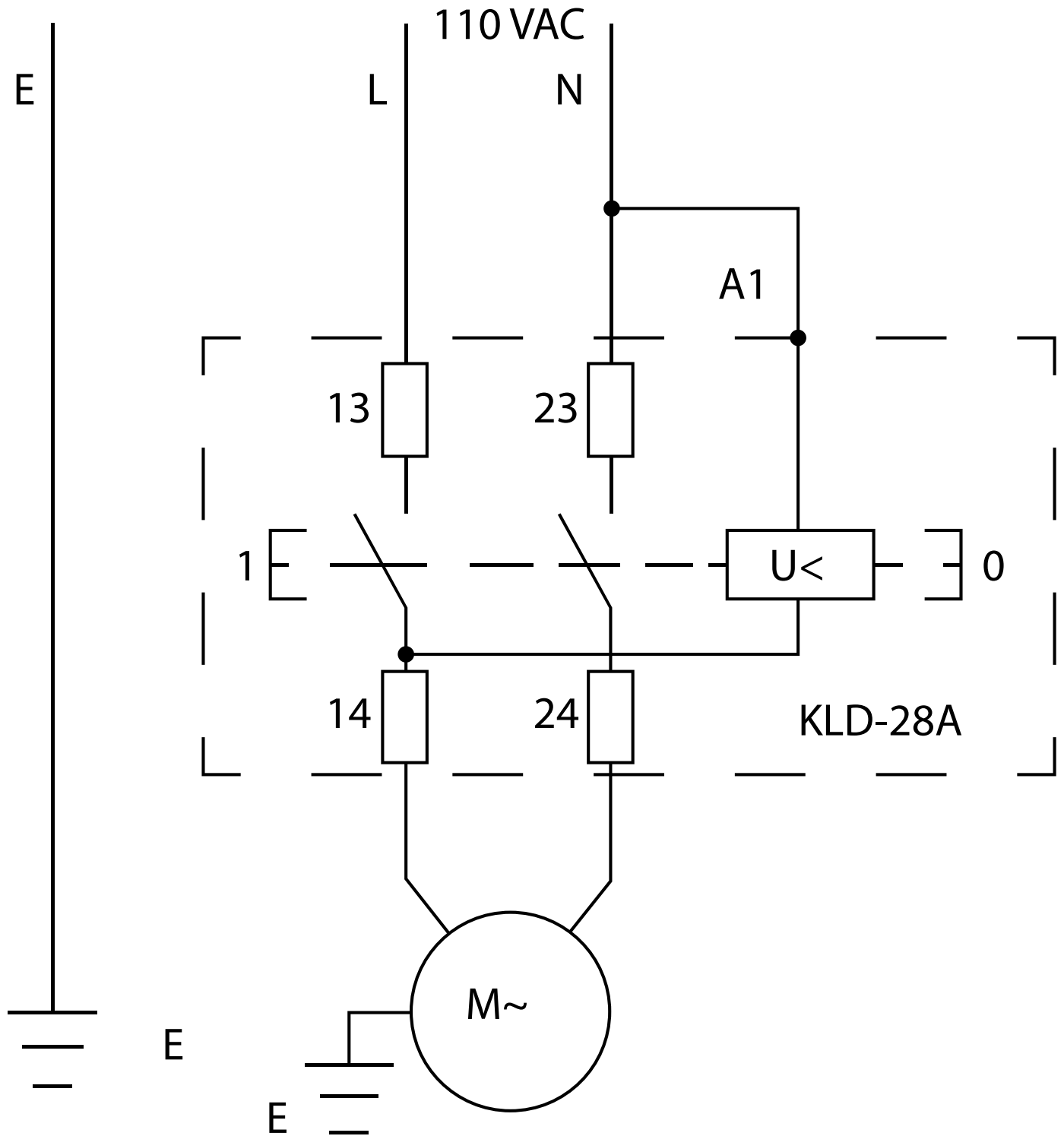



Warranty Registration

Thank you for purchasing an Omcan product. To register your warranty for this product, complete the information below, tear off the card at the perforation and then send to the address specified below. You can also register online by visiting:

Merci d'avoir acheté un produit Omcan. Pour enregistrer votre garantie pour ce produit, complétez les informations ci-dessous, détachez la carte au niveau de la perforation, puis l'envoyer à l'adresse spécifiée ci-dessous. Vous pouvez également vous inscrire en ligne en visitant:

Gracias por comprar un producto Omcan usted. Para registrar su garantía para este producto, complete la información a continuación, cortar la tarjeta en la perforación y luego enviarlo a la dirección indicada a continuación. También puede registrarse en línea en:

<https://omcan.com/warranty-registration/>

For mailing in Canada

Pour postale au Canada

Por correo en Canadá

OMCAN

PRODUCT WARRANTY REGISTRATION

3115 Pepper Mill Court,

Mississauga, Ontario

Canada, L5L 4X5

For mailing in the US

Pour diffusion aux États-Unis

Por correo en los EE.UU.

OMCAN

PRODUCT WARRANTY REGISTRATION

4450 Witmer Industrial Estates, Unit 4,

Niagara Falls, New York

USA, 14305

or email to: service@omcan.com



Purchaser's Information

Name: _____

Address: _____

City: _____ Province or State: _____ Postal or Zip: _____

Country: _____

Dealer from which Purchased: _____

Dealer City: _____ Dealer Province or State: _____

Invoice: _____

Model Name: _____ Model Number: _____

Machine Description: _____

Date of Purchase (MM/DD/YYYY): _____

Would you like to extend the warranty? Yes No

Company Name: _____

Telephone: _____

Email Address: _____

Type of Company:

Restaurant Bakery Deli

Butcher Supermarket Caterer

Institution (*specify*): _____

Other (*specify*): _____

Serial Number: _____

Date of Installation (MM/DD/YYYY): _____

Thank you for choosing Omcan | Merci d'avoir choisi Omcan | Gracias por elegir Omcan



Since 1951 Omcan has grown to become a leading distributor of equipment and supplies to the North American food service industry. Our success over these many years can be attributed to our commitment to strengthen and develop new and existing relationships with our valued customers and manufacturers. Today with partners in North America, Europe, Asia and South America, we continually work to improve and grow the company. We strive to offer customers exceptional value through our qualified local sales and service representatives who provide convenient access to over 5,000 globally sourced products.

Depuis 1951 Omcan a grandi pour devenir un des “leaders” de la distribution des équipements et matériel pour l’industrie des services alimentaires en Amérique du Nord. Notre succès au cours de ces nombreuses années peut être attribué à notre engagement à renforcer et à développer de nouvelles et existantes relations avec nos clients et les fabricants de valeur. Aujourd’hui avec des partenaires en Amérique du Nord, Europe, Asie et Amérique du Sud, nous travaillons continuellement à améliorer et développer l’entreprise. Nous nous efforçons d’offrir à nos clients une valeur exceptionnelle grâce à nos ventes locales qualifiées et des représentants de service qui offrent un accès facile à plus de 5000 produits provenant du monde entier.

Desde 1951 Omcan ha crecido hasta convertirse en un líder en la distribución de equipos y suministros de alimentos en América del Norte industria de servicios. Nuestro éxito en estos años se puede atribuir a nuestro compromiso de fortalecer y desarrollar nuevas relaciones existentes con nuestros valiosos clientes y fabricantes. Hoy con socios de América del Norte, Europa, Asia y América del Sur, que trabajan continuamente para mejorar y crecer la empresa. Nos esforzamos por ofrecer a nuestros clientes valor excepcional a través de nuestro local de ventas y representantes de los servicios que proporcionan un fácil acceso a más de 5,000 productos con origen a nivel mundial.

